



## CAL9 (Not Self-Centering)

Consists of two cone rings, joined through a lock nut and a tab washer. In virtue of the simple design, very fast assembly/disassembly is possible. CAL9 is suitable for applications with medium to low torques. Available for shaft diameters from 14 to 70mm.

### Characteristics

Medium-low torque  
Restricted hub diameter  
Quick installation  
Economical

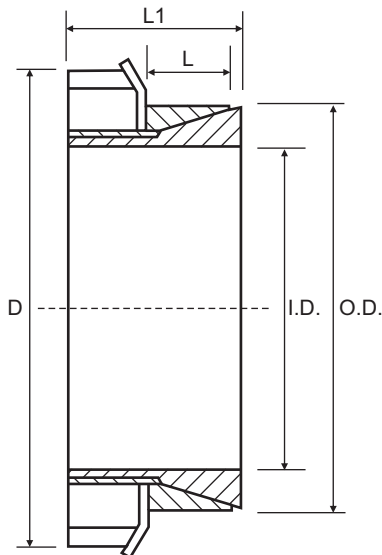

Part No.	I.D.	O.D.	L	L1	D	Torque Nm	Axial Force N
CAL9-14/25	14	25	9	17.0	32	52	7000
CAL9-15/25	15	25	9	17.0	32	56	7000
CAL9-16/25	16	25	9	17.0	32	60	7000
CAL9-17/26	17	26	9	18.0	38	86	10000
CAL9-18/26	18	26	9	18.0	38	91	10000
CAL9-18/30	18	30	9	17.5	38	91	10000
CAL9-19/30	19	30	9	18.0	38	96	10000
CAL9-20/30	20	30	9	18.0	38	102	10000
CAL9-22/32	22	32	9	18.0	45	127	12000
CAL9-24/35	24	35	9	18.0	45	139	12000
CAL9-25/35	25	35	9	18.0	45	144	12000
CAL9-28/36	28	36	10	18.0	52	215	15000
CAL9-28/40	28	40	9	18.0	52	215	15000
CAL9-30/40	30	40	11	20.0	52	230	15000
CAL9-32/42	32	42	11	22.0	58	302	19000
CAL9-35/45	35	45	11	22.0	58	331	19000
CAL9-36/45	36	45	11	22.0	58	340	19000
CAL9-38/48	38	48	14	25.0	65	453	24000
CAL9-40/50	40	50	14	25.0	65	477	24000
CAL9-42/55	42	55	14	26.0	70	576	27000
CAL9-42/57*	42	57	10	25.5	70	370	17000
CAL9-45/55	42	55	14	26.0	70	617	27000
CAL9-45/57*	45	57	10	25.5	70	400	18000
CAL9-48/62	48	62	14	26.0	75	669	28000
CAL9-50/60	50	60	14	26.0	75	697	28000
CAL9-50/62	50	62	14	26.0	75	697	28000
CAL-55/65	55	65	15	27.0	80	796	29000
CAL9-55/68	55	68	15	27.0	80	796	29000
CAL9-56/68	56	68	15	27.0	80	810	29000
CAL9-60/70	60	70	15	29.0	85	946	32000
CAL9-60/73	60	73	15	29.0	85	946	32000
CAL9-63/79	63	79	17	31.0	92	1136	36000
CAL9-65/79	65	79	17	31.0	92	1172	36000
CAL9-70/84	70	84	17	31.0	98	1470	42000

**Torque** = Maximum transmittable torque when axial force is zero.

**Axial Force** = Maximum axial force when transmittable torque is zero.

### For CAL9 use the following tolerances

h8 for the shaft  
H8 for the hub

\* Discontinued size, Limited stock available  
All dimensions in mm unless otherwise stated

## Locking Bush Conversion Chart

SIT (CAL)	TOLLOK (TLK)	Lovejoy (SLD)	MAV	RINGFEDER (RFN)	RINGBLOK	BIKON	COMPOMAC (Conex)	KTR (Clampex)
<b>CAL1</b>	200	1500*	2005	7012	1120	4000	A	100
<b>CAL2</b>	300		3003	8006	1060	5000	C	150
<b>CAL3</b>	110	1900*	5061	7110.1	1100	8000	B*	250
<b>CAL4</b>	450	2600*	4061	7005	1800	1012	F*	400
<b>CAL5A</b>	130		6901	7004	1300.1	7000A	D	200
<b>CAL5B</b>	131		6902	7007	1300.2	7000B	E	201
<b>CAL6</b>	132	1850*	1062	7003	1710	1003	DS	203
<b>CAL7</b>	133	1750*	1061	7006	1720	1006	ES	206
<b>CAL8</b>	134		3061		2400	1506	EP	225
<b>CAL9</b>	250*		3505		1500C	5500SP	H	125
<b>CAL10</b>	500		1004*	7020	1600	9500*	M	700
<b>CAL11S</b>	603	900*	2008	4071	2200.01	1029.71	SD	603
<b>CAL12S</b>	139		4005		1000	4500	L	90
<b>CAL13S</b>	250L		3705		1500	5500S	I	125.1
<b>CAL15</b>	350			7061				

\* External diameters and torque ratings may vary between suppliers

